

Multimortar

Firestop Mortar



Fire resistance
≤ 240 minutes



Acoustic insulation
Rw 64 dB



Working life
30 years



Paintable
After 4 hrs

Firestop Mortar

Multimortar is a dry white powder consisting of non-organic compounds and perlite. When these are mixed with water, the compounds form a strongly thermal and insulating fire-resistant mass. In the event of fire, this mortar prevents fire and smoke from spreading through fire-resistant walls and floors. After having sealed openings with Multimortar, the wall or floor will retain its excellent acoustic properties.

Multimortar forms part of the Mulcol® Penetration Seal System. The Multimortar can be used in combination with the Multicollar Slim, Multiwrap and Multimastic FB firestop boards.

Advantages

- ✓ CE-certified
- ✓ Very high acoustic insulation
- ✓ Easy to install
- ✓ Smooth finish
- ✓ High degree of mechanical resistance
- ✓ Suitable for most surfaces
- ✓ Opening size floors and walls: 2400 x 1200 mm

Applications

- ✓ Rigid floors and walls
- ✓ Flexible walls
- ✓ Metal pipes up to Ø 324 mm with insulation
- ✓ Cable trays, cable ladders, electric cables and cable bundles
- ✓ Plastic pipes up to Ø 40 mm without fire collar
- ✓ Blank seals

Technical data

Colour	Off-white
Shelf life	Unlimited shelf life when unopened bag is stored in a dry place at more than +5 °C
Application temperature	0 °C to +40 °C
Temperature resistance	-20 °C to +70 °C
Hardened	Less than one hour, depending on the local climate, fully hardened after 30 days
LEED VOC	10 g/l
Reaction to fire	Class A1 in accordance with EN 13501-1

Packaging

	Contents	Pallet	Pallet	Article number
Bag	20 litres	63 bags	1260 litres	209001020

Consumption

Approximately 2.94 bags per m² with a thickness of 50 mm

Approximately 5.88 bags per m² with a thickness of 100 mm

Technical documents available

- ✓ Product Data Sheet (PDS)
- ✓ Technical Data Sheet (TDS)
- ✓ Safety Data Sheet (SDS)
- ✓ Installation Manual
- ✓ EC certificate 0843-CPR-0329
- ✓ Emission reports
- ✓ Acoustic report no. BMT/MTZ/F13079/04/AR2

Approvals

- ✓ Tested in accordance with EN 1366-3
- ✓ Classification in accordance with EN 13501-2
- ✓ Certified in accordance with ETAG 026-2
- ✓ ETA report 16/0566
- ✓ Declaration of Performance (DoP) no. PSS-MM 0843-CPR-0329

The above documents are available from your Mulcol contact person or via www.mulcol.com



BMTRADA

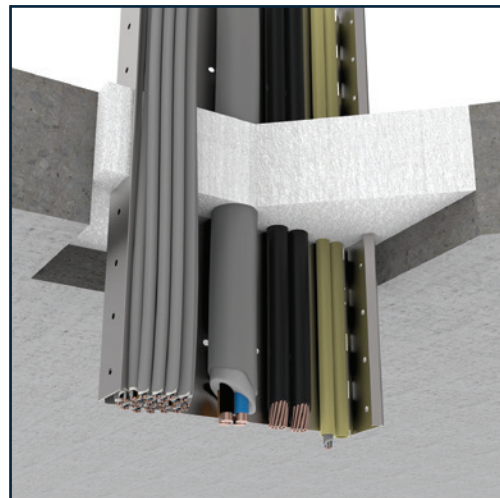
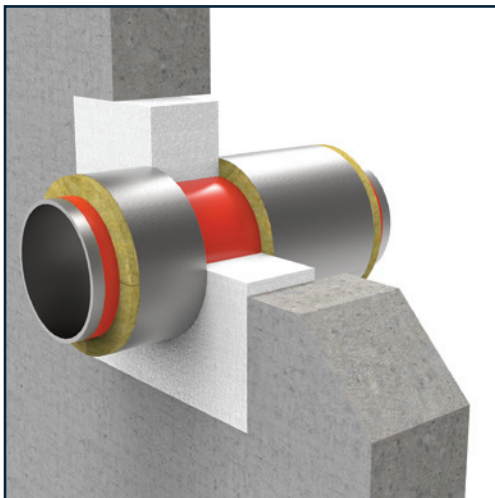

Virtual Reality



Augmented Reality



Information



Mulcol International composed the technical data on this sheet with great care and reserves the right to change product properties without prior notification. The user of this data remains responsible at all times for the correct application thereof. In the event of a lack of clarity or doubt, we recommend consulting Mulcol International to confirm that this data complies with the required application.

