

# Multifoam Stone

Fire Protection Stone



**Fire resistance**  
≤ 120 minutes



**Acoustic insulation**  
Rw 49 dB



**Working life**  
30 years



**Resistant against**  
fungi and bacteria

## Fire Protection Stone

Multifoam Stone is a foaming two-component polyurethane foam in the shape of a stone with fire-retardant additives for the fire-resistant sealing of openings around cable trays, cable bundles, flammable and non-flammable pipes. In the event of fire, the stone prevents fire and smoke from spreading through fire-resistant walls and floors.

Multifoam Stone forms part of the Mulcol® Multifoam 2K System. Multifoam Stone is used in combination with Multifoam 2K and can be combined with the Multifoam Wrap in order to realise fire-resistant seals of up to 120 minutes for cable trays, cable ladders, electric cables and cable bundles.

### Advantages

- ✓ CE-certified
- ✓ Easy to install
- ✓ Clean processing
- ✓ Efficient processing, no waste
- ✓ Permanently elastic and high acoustic insulation
- ✓ Cable mutations after installation possible
- ✓ Excellent adhesion on virtually all surfaces
- ✓ Working life of 30 years

### Applications

- ✓ Rigid walls and floors
- ✓ Flexible walls
- ✓ Plastic pipes up to Ø 50 mm
- ✓ Metal and copper pipes with and without insulation
- ✓ Cable trays, cable ladders, electric cables and cable bundles
- ✓ Aluminium composite pipes with and without insulation

### Technical data

Colour	Red/brown
Shelf life	12 months in unopened packaging at a temperature between +5 °C and +30 °C
Application temperature	0° C to +50 °C
Temperature resistance	-20 °C to +80 °C
French VOC	< 2 µg/m <sup>3</sup>
Reaction to fire	Class E in accordance with EN 13501-1

## Packaging

	Dimensions	Box	Pallet	Pallet	Article number
Stone	200 x 144 x 60 mm	18 pieces	20 boxes	360 pieces	303001200

## Technical documents available

- ✓ Product Data Sheet (PDS)
- ✓ Safety Data Sheet (SDS)
- ✓ Technical Data Sheet (TDS)
- ✓ Installation Manual
- ✓ EC certificate
- ✓ Emission reports

## Approvals

- ✓ Tested in accordance with EN 1366-3
- ✓ Classification in accordance with EN 13501-2
- ✓ Certified in accordance with ETAG 026-2
- ✓ ETA report 17/0831
- ✓ Declaration of Performance (DoP)

The above documents are available from your Mulcol contact person or via [www.mulcol.com](http://www.mulcol.com)

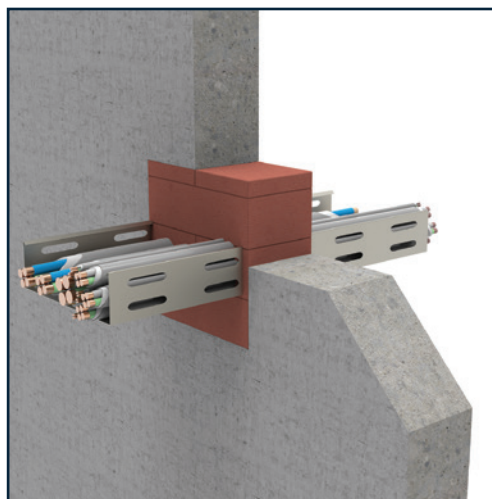
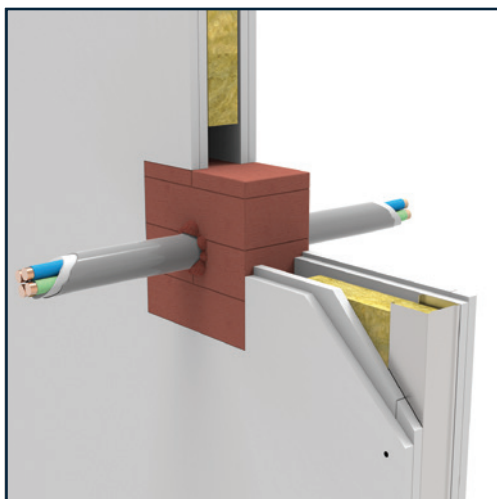

Virtual Reality



Augmented Reality



Information



Mulcol International composed the technical data on this sheet with great care and reserves the right to change product properties without prior notification. The user of this data remains responsible at all times for the correct application thereof. In the event of a lack of clarity or doubt, we recommend consulting Mulcol International to confirm that this data complies with the required application.